



MODEL H8119 3/8" IMPACT WRENCH w/FRONT EXHAUST INSTRUCTION SHEET

⚠ WARNING



EYE INJURY HAZARD!
Always wear safety glasses during use to prevent serious personal injury.

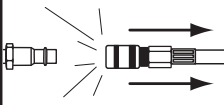

INJURY HAZARD!
When servicing, always disconnect tool from air to prevent unexpected operation.

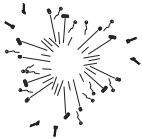

**120 PSI
MAX AIR PRESSURE!**
Exceeding this PSI may result in injury/tool damage.



Figure 1. Model H8119.

Specifications

Drive Size	3/8"
Free Speed.....	7,000 rpm
Maximum Torque	145 ft/lb.
Air Inlet	1/4" NPT
Average Air Consumption	4 cfm
Weight	3.3 lbs.

Inventory

- A. Impact Wrench 1
- B. Oil Bottle..... 1

Operation

Tool requires 90 PSI to operate correctly.

To improve tool lifespan, use a filter/lubricator/regulator as shown in **Figure 2**.

Otherwise, lubricate multiple times daily with 2–3 drops of pneumatic tool oil. Insert the oil directly into the air fitting as shown in **Figure 3**.

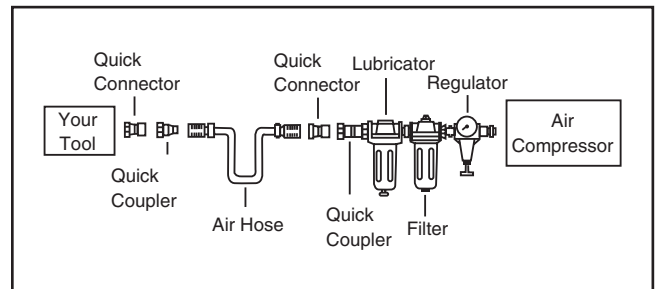

Figure 2. Installing your tool.

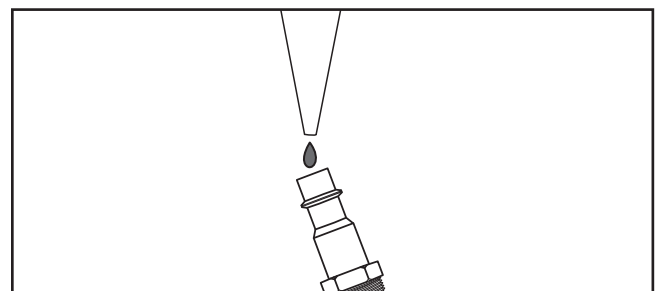

Figure 3. Lubricating directly into air fitting.

If you need help with your new pneumatic tool, call our Tech Support at: (570) 546-9663.

COPYRIGHT © JANUARY, 2007 BY GRIZZLY INDUSTRIAL, INC.

WARNING: NO PORTION OF THIS MANUAL MAY BE REPRODUCED IN ANY SHAPE OR FORM WITHOUT THE WRITTEN APPROVAL OF GRIZZLY INDUSTRIAL, INC.

#TR8963 PRINTED IN TAIWAN

H8119 Parts Breakdown and List

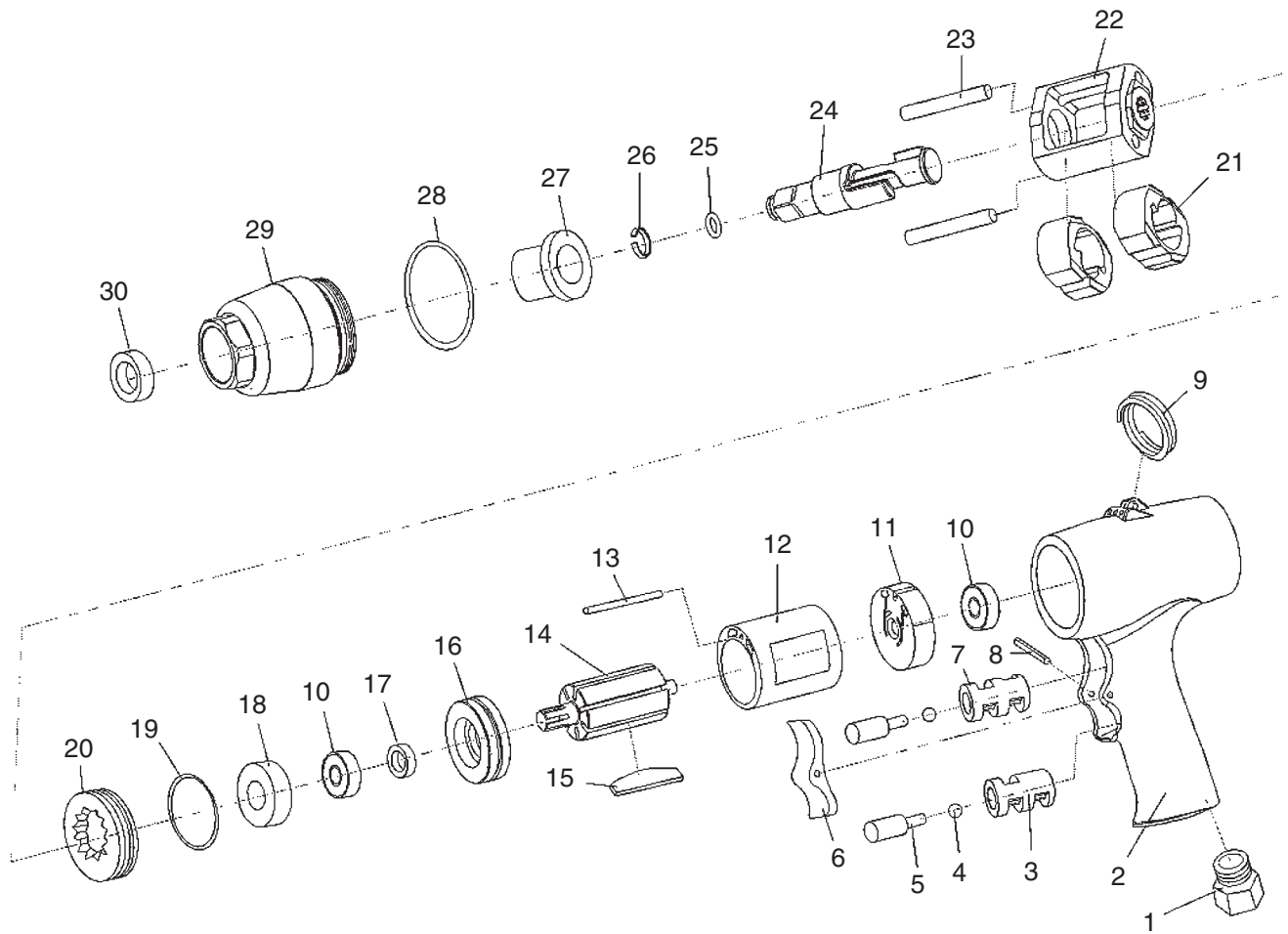

REF	PART #	DESCRIPTION
1	PH8119001	AIR INLET 1/4" NPT
2	PH8119002	HOUSING
3	PH8119003	END SLEEVE
4	PH8119004	VALVE STEM
5	PH8119005	TRIGGER PIN
6	PH8119006	TRIGGER
7	PH8119007	FRONT SLEEVE
8	PH8119008	GROOVE PIN
9	PH8119009	LANYARD RING
10	PH8119010	BEARING
11	PH8119011	REAR END PLATE
12	PH8119012	CYLINDER
13	PH8119013	CYLINDER DOWEL
14	PH8119014	VANE SET
15	PH8119015	ROTOR

REF	PART #	DESCRIPTION
16	PH8119016	FRONT END PLATE
17	PH8119017	ROTOR OIL SEAL
18	PH8119018	ROTOR SLEEVE
19	PH8119019	O-RING 37 X 2.65MM
20	PH8119020	LOCKING RING
21	PH8119021	HAMMER
22	PH8119022	HAMMER FRAME
23	PH8119023	HAMMER PIN
24	PH8119024	ANVIL
25	PH8119025	O-RING 4.5 X 1.3MM
26	PH8119026	SOCKET RETAINER
27	PH8119027	HAMMER CASE BUSHING
28	PH8119028	O-RING 41.2 X 2.65MM
29	PH8119029	HAMMER CASE BUSHING
30	PH8119030	OIL SEAL